

- 1 - UNIT PANELS
- 2 - REFRIGERANT SYSTEM AIR COOLED
- 3 - REFRIGERANT SYSTEM WATER COOLED
- 4 - WATER SYSTEM
- 5 - CONTROL BOX AND P.C. BOARD

1 - UNIT PANELS

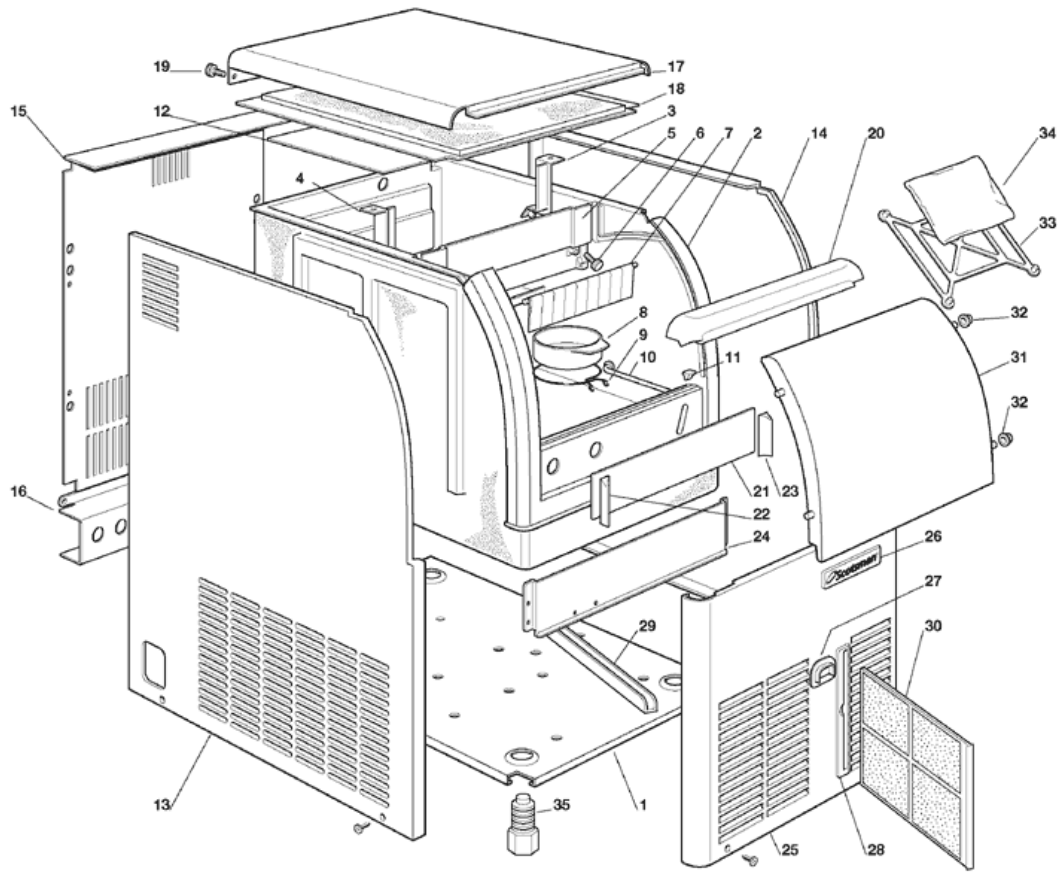

1 - UNIT PANELS

POSITION	CODE	DESCRIPTION
0001	702386 00	UNIT BASE
0002	782101 00R	INSULATED STORAGE BIN
0003	660778 00	CURTAIN BRACKET RIGHT
0004	660778 01	CURTAIN BRACKET LEFT
0005	660775 00	CURTAIN BRACKET UPPPER
0006	650806 05	THUMB SCREW
0007	784457 07R	CURTAIN ASSY
0008	660741 00	PLASTIC PLUG
0009	460047 00	SPRING
0010	732017 00	BULB HOLDER
0011	660816 00	SHOCK ABSORBER
0012	742033 04	EVAPORATOR COVER
0013	721947 00	PANEL, LEFT SIDE
0014	721946 00	PANEL, RIGHT SIDE
0015	702387 00	PANEL, REAR
0016	702388 00	BRACKET
0017	721949 00	PANEL, TOP
0018	650900 00	INSULATION, TOP
0018	660822 00	PLASTIC COVER
0019	650806 00	THUMB SCREW
0020	660776 00	FRONT LINER
0021	721970 00	FRONT PLATE
0022	660830 01	CORNER PROTECTION LEFT
0023	660830 00	CORNER PROTECTION RIGHT
0024	704202 00	BRACKET, FRONT
0025	721948 00	PANEL, FRONT - AIR COOLED
0025	721948 01	PANEL, FRONT - WATER COOLED
0026	650850 00	LOGO, SCOTSMAN
0027	660829 00	FRONT SWITCH PLASTIC PROTECTION
0028	660804 00	AIR FILTER SEAT
0029	660838 00	SLIDE, AIR FILTER
0030	660805 00	AIR FILTER
0031	660814 00	BIN DOOR
0032	660286 00	BUSHING
0033	660831 00	RUBBER BRACKET, SANITISING BAG
0034	650909 00	SANITISING BAG
0035	650382 01	LEG

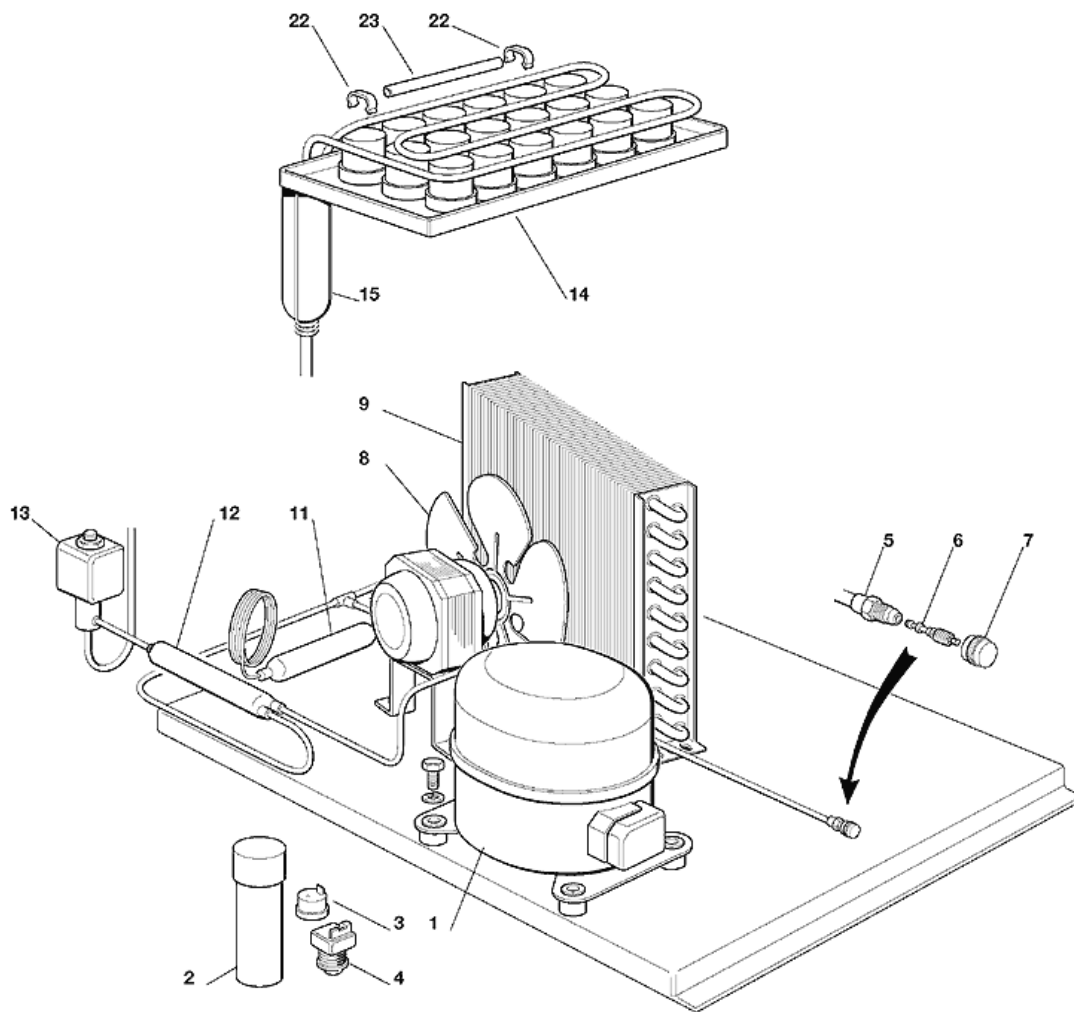



2 - REFRIGERANT SYSTEM AIR COOLED

POSITION	CODE	DESCRIPTION
0001	670100 00	COMPRESSOR - 230/50/1
0002	620167 29	START CAPACITOR 47MFD/330V
0003	620478 03	PROTECTOR 230/50
0004	620057 35	RELAY - 230/50
0005	650109 00	VALVE BODY
0006	670012 00	VALVE CORE
0007	650106 00	CAP
0008	620419 02	FAN MOTOR - 230/50-60
0008	620419 32	FAN BLADE
0008	620419 61	FAN MOTOR BRACKET
0009	620276 02	CONDENSER
0011	630003 05	DRIER
0012	630137 00	MECHANICAL FILTER
0013	620306 22	HOT GAS VALVE BODY
0013	620306 48	COIL - 230/50-60
0014	784615 00	EVAPORATOR ASSY
0015	784632 00	SUCTION LINE ASSY
0022	650475 02	METAL CLIP
0023	741114 00R	PLASTIC BULB HOLDER

3 - REFRIGERANT SYSTEM WATER COOLED

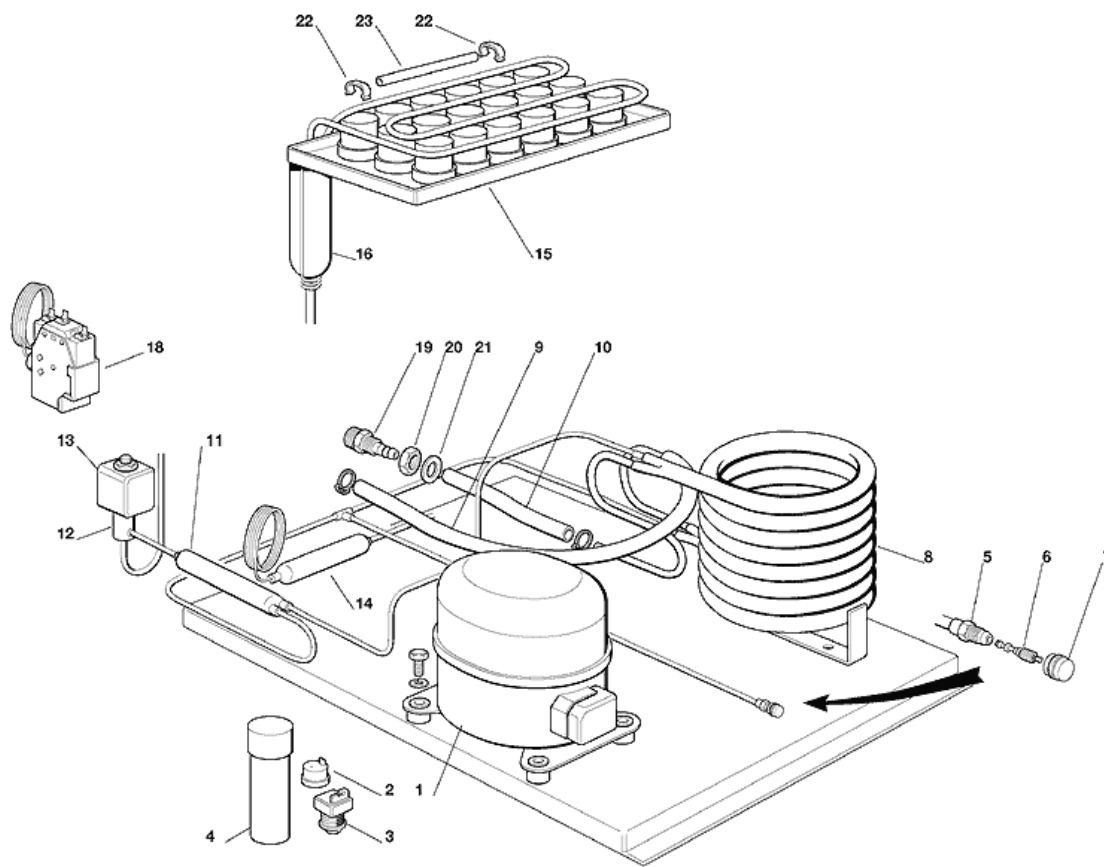



3 - REFRIGERANT SYSTEM WATER COOLED

POSITION	CODE	DESCRIPTION
0001	670100 00	COMPRESSOR - 230/50/1
0002	620167 29	START CAPACITOR 47MFD/330V
0003	620478 03	PROTECTOR 230/50
0004	620057 35	RELAY - 230/50
0005	650109 00	VALVE BODY
0006	670012 00	VALVE CORE
0007	650106 00	CAP
0008	620389 02	CONDENSER
0009	281900 01	TUBE 16X10
0010	281900 01	TUBE 16X10
0011	630137 00	MECHANICAL FILTER
0012	620306 22	HOT GAS VALVE BODY
0013	620306 48	COIL - 230/50-60
0014	630003 05	DRIER
0015	784615 00	EVAPORATOR ASSY
0016	784632 00	SUCTION LINE ASSY
0018	620075 00	PRESSOSTAT
0022	650475 02	METAL CLIP
0023	741114 00R	PLASTIC BULB HOLDER

4 - WATER SYSTEM

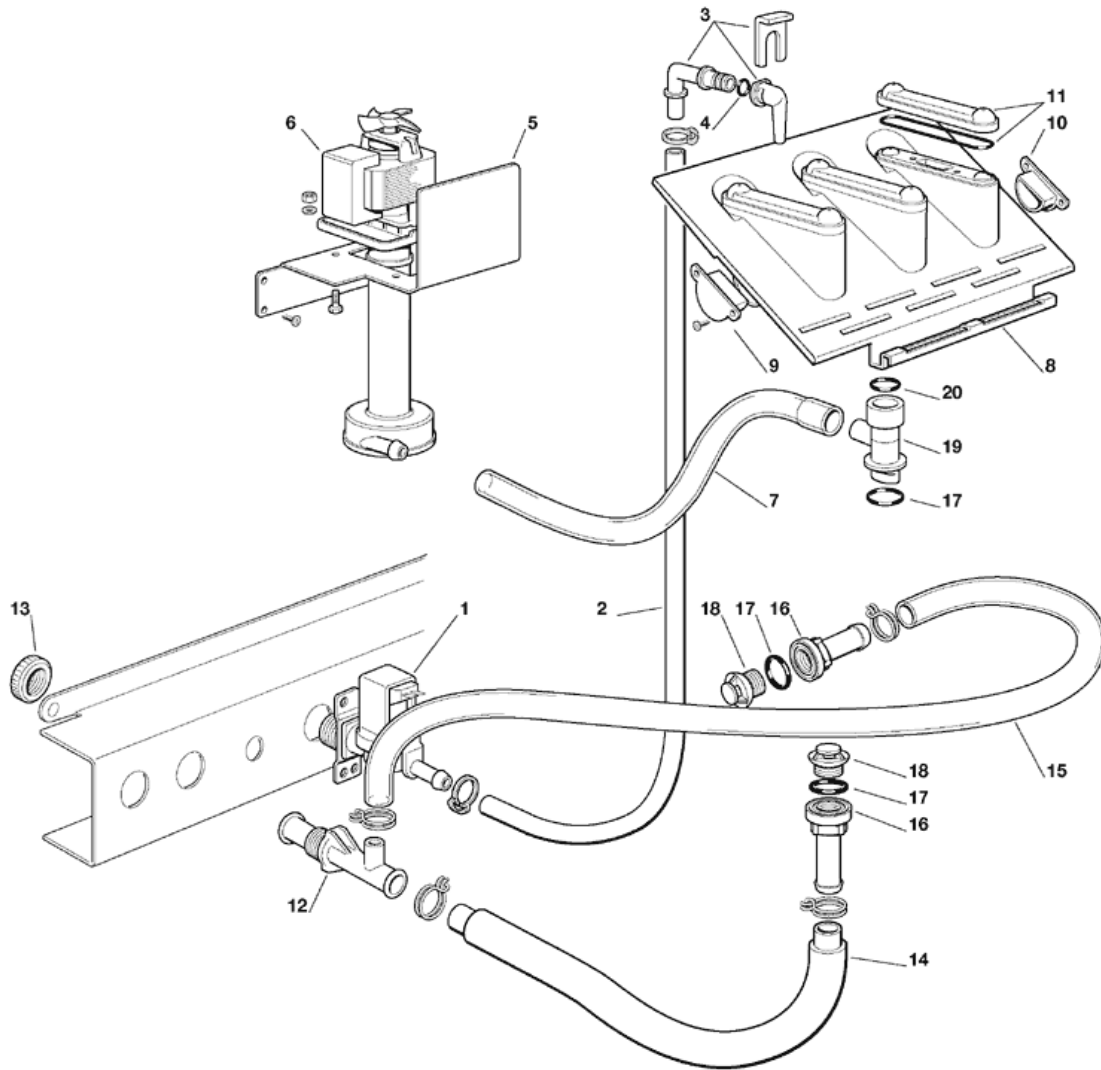

4 - WATER SYSTEM

POSITION	CODE	DESCRIPTION
0001	650105 64	WATER INLET VALVE ASSY - AIR COOLED
0001	650105 68	WATER INLET VALVE ASSY - WATER COOLED
0002	281900 01	TUBE 16X10
0003	793172 00R	WATER INLET ELBOW ASSY
0004	640041 31	O RING
0005	721986 00	METAL BRACKET
0006	620433 00	WATER PUMP 230/50
0006	620433 01	WATER PUMP 230/60
0007	610150 03	TUBE
0008	793129 09	SPRAY SYSTEM ASSY
0009	660520 07	PLASTIC PLUG
0010	660520 06	PLATIC PLUG
0011	060529 01	SPRAY COVER KIT GREY
0012	660224 00	TEE TUBE
0013	660535 00	PLASTIC NUT
0014	610148 10	TUBE
0015	610204 00	TUBE
0016	660219 01	BIN DRAIN
0017	640134 00	O RING 4093
0018	660211 01	DRAIN FILTER
0019	660777 00	SPRAY SYSTEM SEAT
0020	640041 32	O RING

5 - CONTROL BOX AND P.C. BOARD

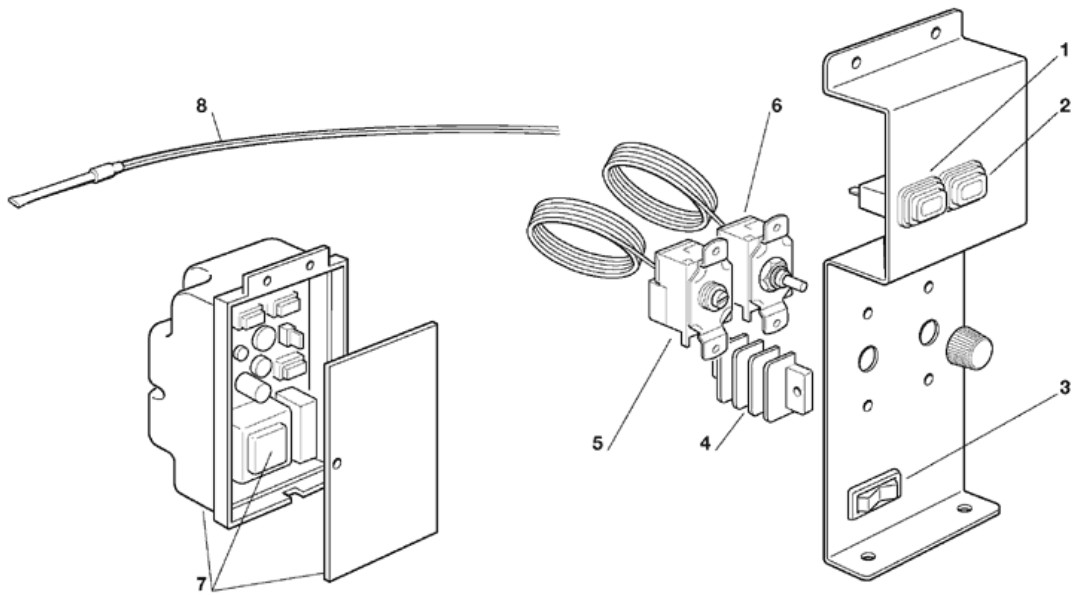

5 - CONTROL BOX AND P.C. BOARD

POSITION	CODE	DESCRIPTION
0001	620487 01	WARNING LIGHT - RESET BUTTON
0002	620487 00	MASTER LIGHTED SWITCH
0003	620442 01	SWITCH
0004	630114 01	TERMINAL BOARD
0005	630005 00	BIN THERMOSTAT
0006	620264 16	EVAP. THERMOSTAT
0007	785104 00R	PC BOARD ASSY - CLEANING REMIND
0008	620404 11	CONDENSER SENSOR